

THE CITY OF NAPOLEON

BUILDING & ZONING DEPARTMENT

255 W. RIVERVIEW

(419)592-4010

Sign Permit

Page 1 of 1

Permit Number: SG2005-2

Printed: 2/17/2005

Property Address: 1421 Scott St. N.

Applicant

Harmon Signs
Address: 7844 W Central Ave

Approval Date:

Toledo, OH 43617

Phone: 419-841-6656

Owners

Name: Snyder Pontiac
Address: 1421 N. Scott St

Contractors

Harmon Signs
Address: 7844 W Central Ave
Toledo, OH 43617

Phone 419-841-6656

Fees and Receipts:

Number	Description	Amount
FEE2005-156	Total sq footage of sign (s) (Au	\$25.00
Total Fees:		\$25.00

Description of work to be done:

50
0
0
0
0
0
0

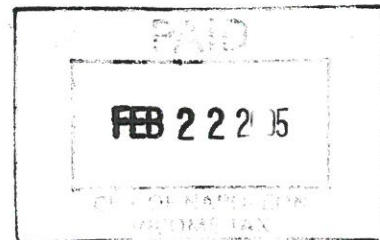

Current Signs:

Proposed Signs:

Applicant signature: *AS - mailed in*

Date: _____

THE CITY OF NAPOLEON

BUILDING & ZONING DEPARTMENT

255 W. RIVERVIEW

(419)592-4010

Sign Permit

Page 1 of 1

Permit Number: SG2005-3

Printed: 2/17/2005

Property Address: 1421 Scott St. N.

Applicant

Address: Harmon Signs
7844 W Central Ave

Toledo, OH 43617

Approval Date:

Phone: 419-841-6656

Owners

Name: Snyder Pontiac
Address: 1421 N. Scott St

Contractors

Harmon Signs
Address: 7844 W Central Ave
Toledo, OH 43617

Phone 419-841-6656

Fees and Receipts:

Number	Description	Amount
FEE2005-157	Total sq footage of sign (s) (Au	\$32.70
Total Fees:		\$32.70

Description of work to be done:

127
0
0
0
0
0
0

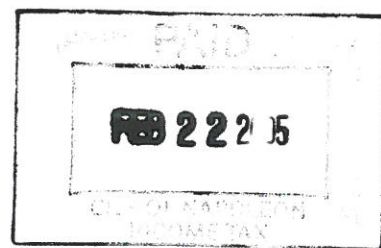

Current Signs:

Proposed Signs:

Applicant signature: *AS - mailed in*

Date:

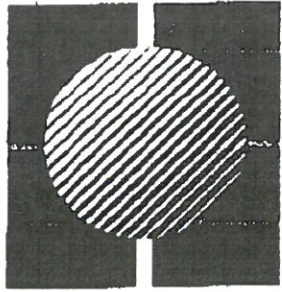

**HARMONSIGN
PLANETNEON**

▶ *facsimile
cover sheet*

Toledo, OH.43617

7844 W. Central Ave.
Ph 419.841.6656 Fax 419.841.7160

DATE: 2.3. 2005

NUMBER OF PAGES _____ INCLUDING COVER SHEET

TO: TOM FIRM: _____

FROM: SUE FAX NUMBER: 599.8393

RE: _____

MESSAGE AREA

*Pl. call & let me know if
my figures match yours.*

*THANKS,
SUE*

City of Napoleon
Engineering Department

Office Use Only	
Permit No:	_____
App. Date:	_____
Est. Cost:	_____
Base Fee:	_____
Plus Fee:	_____
Total Fee:	_____

Application for Sign Permit

Owner Name: SNYDER PONTIAC

Owner Address: 1421 N. SCOTT ST.

Contractor Name: HARMON SIGN

Contractor Address: 1844 W. CENTRAL TOLEDO, OH 43617
PH: 419.841.6656

Location of Project: 1421 N. SCOTT ST

Additional Information: Sign Type - Post Wall Ground Awning

Dimensions: SEE ATTACHED Total S.F. _____

Date: 2.3.05 Applicant Signature: [Signature]

Application must include a site drawing or a description of the location of the sign (where applicable) and a sketch of the proposed sign(s).

The permit fee is as follows: \$25.00 base which includes up to 50 square feet of sign area, plus .10 per square foot after 50 square feet, not to exceed \$100.00 in any case.

LEADING EDGE OF SIGNS TO BE
10' FROM PROPERTY LINE. SIGNS
WILL BE INSTALLED JUST NORTH
OF EXISTING SIGNS.

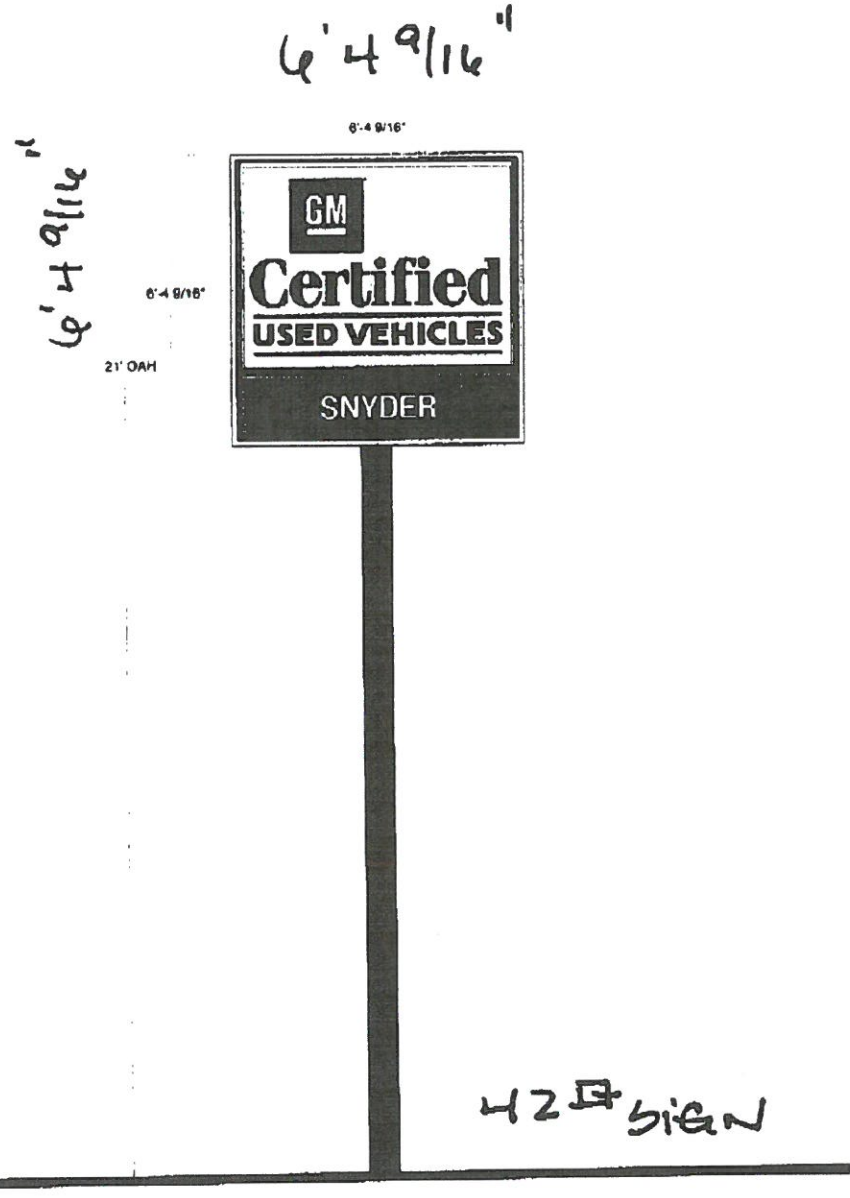

Account GM
 Project Title GM P38 CUV (R2) 11/04/04
 Scale 1:32
 Date Created 2 FEB 05

Drawn By R. KECK
 IP Rep. Z. BROWN
 Approved By
 Date Revised XXXXXXX

04-1089 Pg 1 of 1

All copies, plans or change orders shall be submitted to the drawing office and shall not be reproduced, used for or disclosed to any person, firm or organization for any purpose whatsoever without written permission of ImagePoint.

ImagePoint.
 PO Box 52033
 Knoxville, TN 37950-0043
 1.800.444.7456
 www.imagepoint.com

BASE SIGN (50#) \$25.00

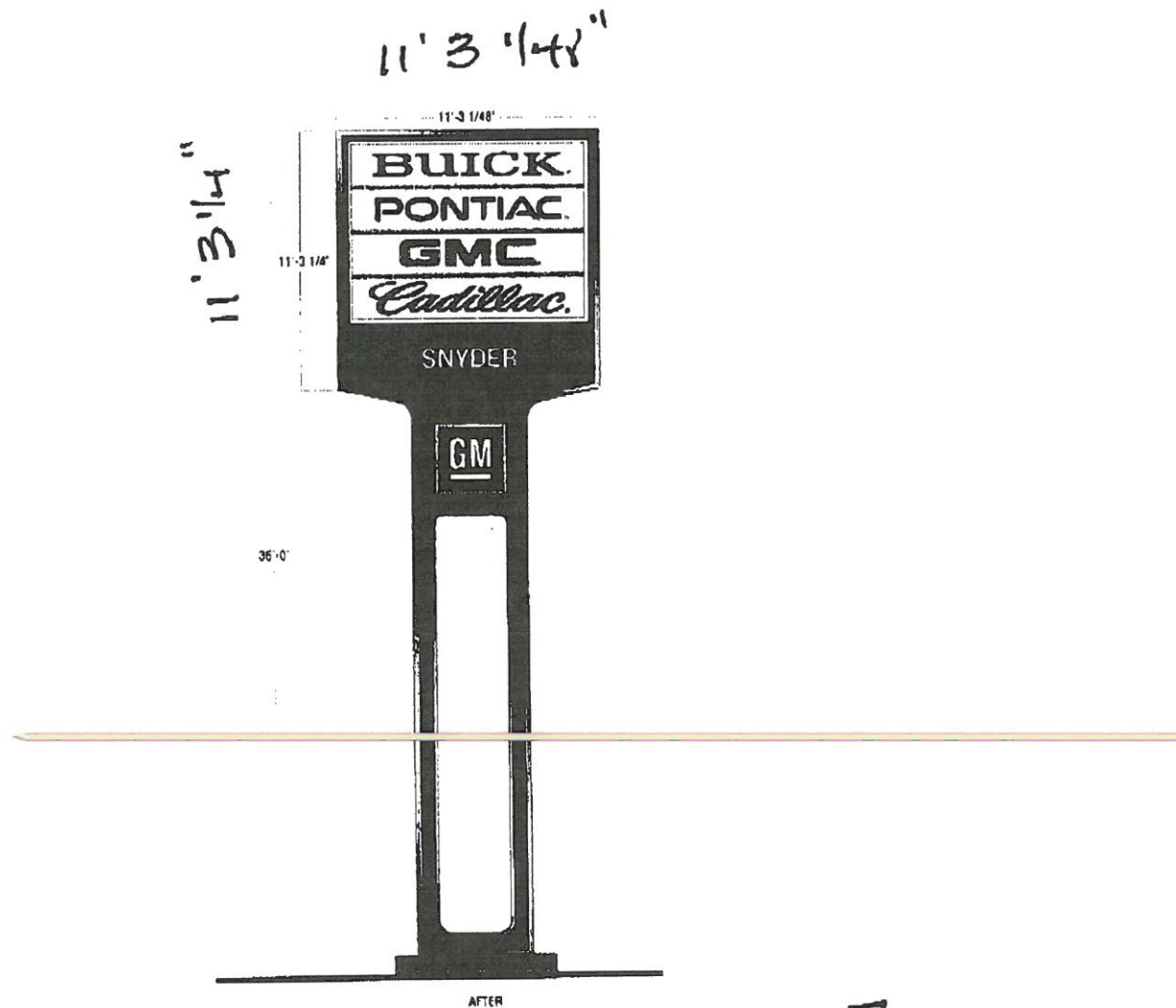

127 sq sign

Account GM
 Project Title GM P137 6 P GMCK W38' w IP Rep. E. DULANEY
 Scale 1:50
 Date Created 02 FEB 05

Drawn By R. KECK
 IP Rep. E. DULANEY
 Approved By
 Date Revised Jx Jax 2002

All work must be in accordance with the requirements of this contract. No work shall be done without the written permission of ImagePoint.

ImagePoint.

PO Box 50012
 Knoxville TN 37950-0112
 1-800-444-7710
 www.imagepoint.com

04-0472 Pg 1 of 1

BASE SIGN (50 sq) \$25.00
 77 sq ADDITIONAL 7.70
 \$32.70

